

# How to use a Harmonics and Flicker Generator (HFG) to check harmonics and flicker test setup

The details of the methods described in the harmonics measurement standard (EN 61000-3-2) for determining the levels of harmonics and their associated limits mean that fully exercising the measuring equipment is only practical at periodic calibration intervals. Regular verification should be undertaken using equipment drawing a stable, harmonic rich current waveform.

The availability of proprietary sources for verifying and monitoring the performance of harmonics and flicker measuring equipment is limited, and some pre-test verifications are performed using “home made” solutions based on half-wave rectifiers and resistive loads. The stability of the resistive loads is called into question when temperature sensitive or non linear devices are used, such as filament lamps. In addition, half-wave rectifiers generate predominantly even-order harmonics. Most electronic equipment drawing current from the mains supply employs AC to DC conversion using full-wave rectification to feed a reservoir capacitor, and this topology generates predominantly odd-order harmonics. This may be significant when assessing the results or using the pre-test to exercise any test standards based software used to run the test setup and automatically assess the performance of the EUT.

For flicker measurements, the specification of the flickermeter described in IEC 61000-4-15 makes it difficult to predict the expected flicker from a known waveshape without extensive calculation and analysis. Hence the verification for this test is probably best left as a simple repeatability exercise using a source of disturbance.

In order to verify the flicker test the simplest method is to apply a known deviation at a stable repetition rate. This voltage deviation, which is the result of drawing current from a source with series impedance, can be generated by the regular switching of a stable resistive load, as shown in Figure 1. The resultant level of flicker disturbance is constant and repeatable and hence is suitable for a simple verification check on the flicker equipment. A deviation of around 0.3% is sufficient enough to produce significant flicker levels.

The HFG01 provides a number of load profiles intended to provide reference test results that can be used to verify correct test equipment operation. The four profiles provided are:

- a fixed current pulse, representative of the current drawn under full-wave rectification, which produces predominantly odd-order harmonics (see Figure 2).
- a current similar to the one above, but which fluctuates between narrow and wide pulse widths. The choice of pulse-widths reflects the equipment Class D description used in EN 61000-3-2 (prior to amendment A14) and is intended to exercise the “judgemental” aspects of some test software used to determine pass or fail verdicts.
- a resistive load switched in and out of circuit at a rate of 1 Hz, used to generate flicker.
- the same resistive load, but switched at a rate of 8.33 Hz. This produces the same level of voltage disturbance, but a greater degree of flicker than the 1 Hz mode.

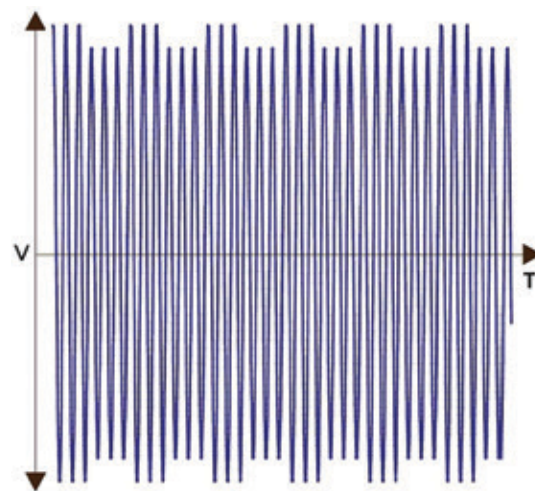
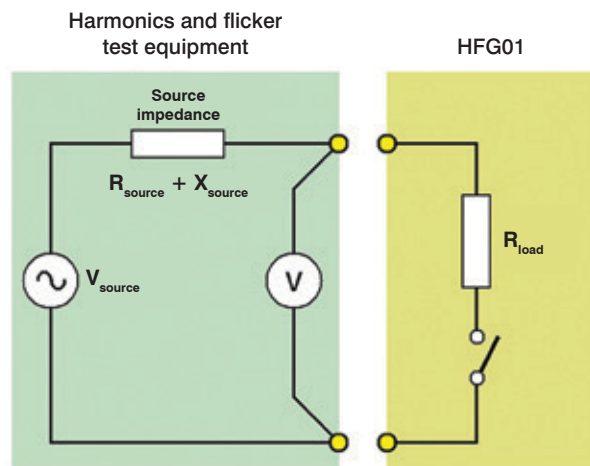

Figure 1. Generating flicker disturbance

## Procedure

To perform the pre-test check the HFG01 is simply substituted in place of the EUT. This has the benefit of testing the total system; the power source, source impedance and power analyser. To assess the harmonics measurement, for example, either of the HFG01 harmonic modes is selected and the appropriate test then run. The test setup for such a verification is not usually critical, as at low frequencies the interactions with the environment are at sufficiently low levels so as not to interfere with the measurement result. A photograph showing a harmonics verification together with an example result can be seen in Figures 3 and 4.

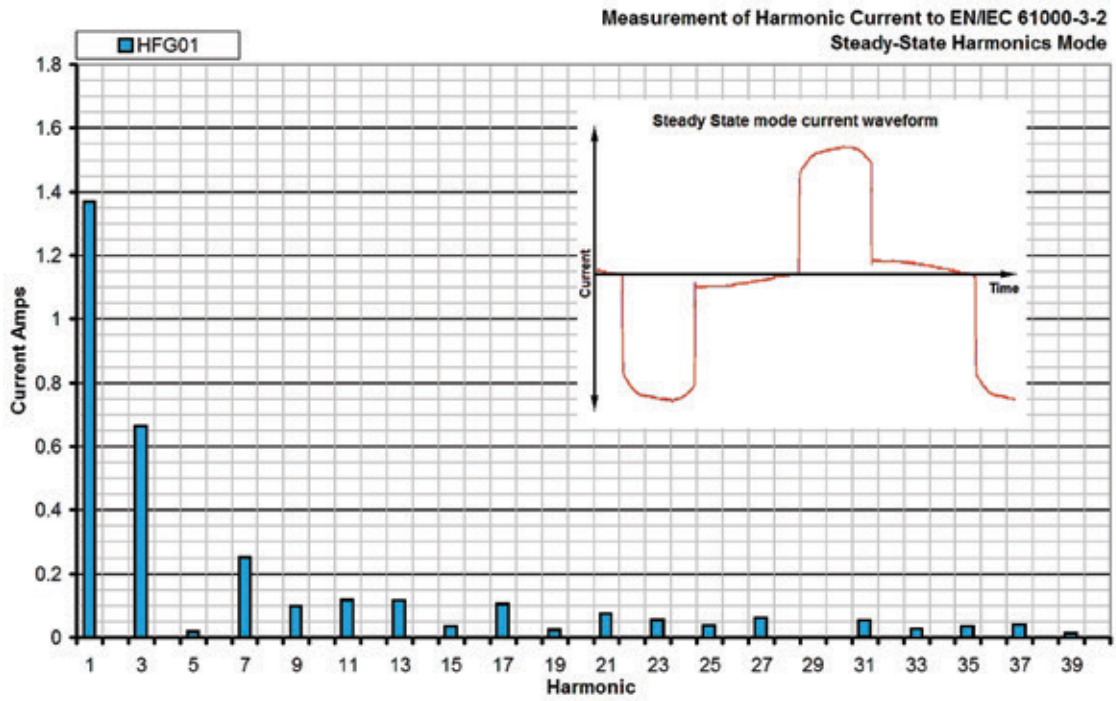

Figure 2. Fixed current pulse drawn by the HFG01 and its resultant harmonic spectrum



Figure 3. Harmonics pre-test using the HFG01 as the reference load

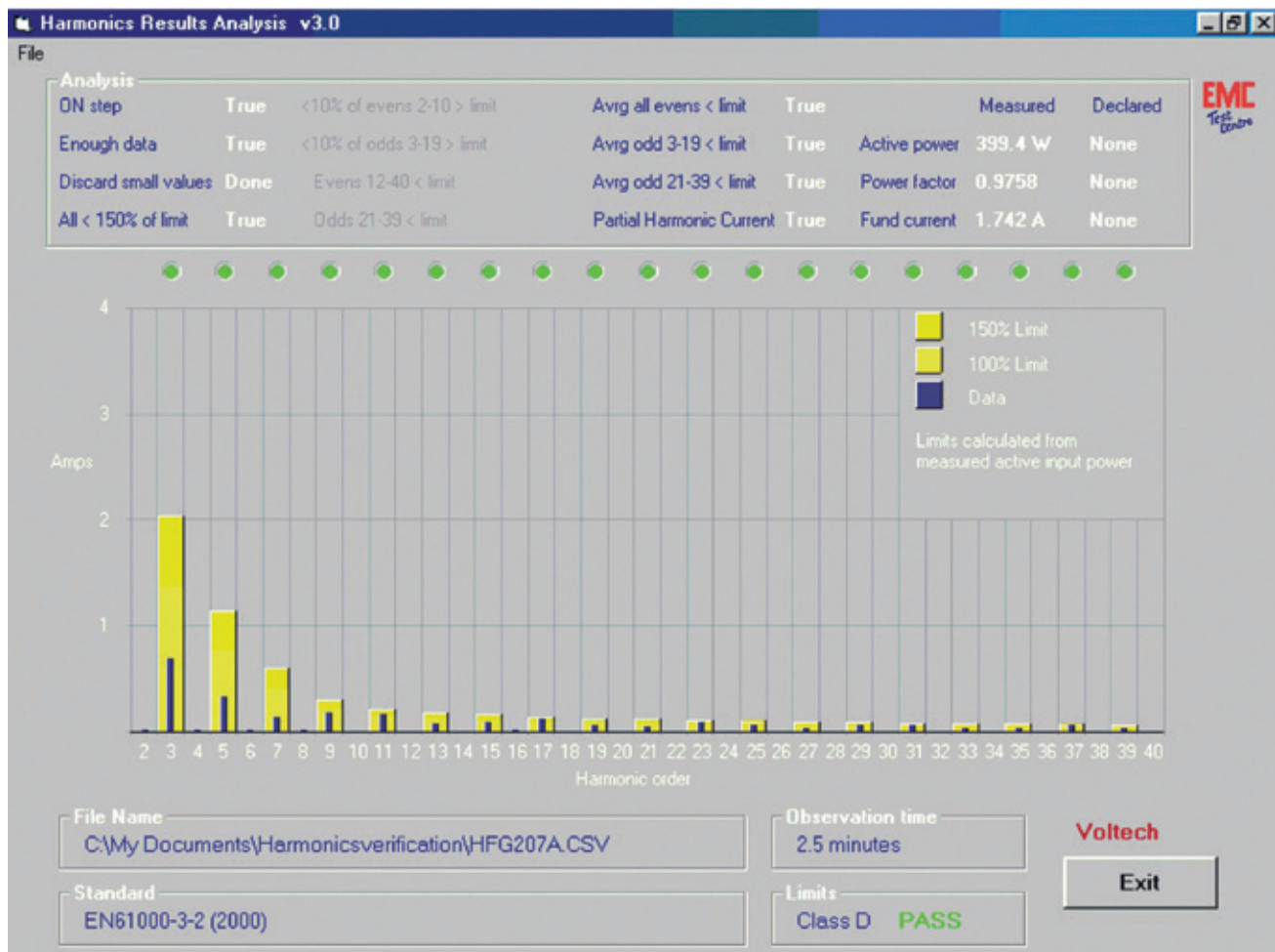

Figure 4. Results from the harmonics test software.

As can be seen, the harmonic currents generated are close to the acceptable limit in several places. In fluctuating harmonics mode the two current pulse widths straddle the points used to define the Class D category in EN 61000-3-2:1995, and this mode would be expected to result in a Class D fail verdict (although it may alternatively be reported as a Class A pass depending on the test software configuration).

For flicker measurements, the two settings are designed to provide a pass and fail response from the test software. Although the same level of voltage disturbance is generated in both cases, when applied at 1 Hz this should result in a short term flicker (Pst) of <1, whereas at 8.33 Hz this should result in a Pst >1, due to the human model of perceived "annoyance" being most sensitive around 8 Hz.

There are several issues that can arise when performing such measurements. Notably, there appears to be a large degree of measurement uncertainty associated with these tests. Sensitivity to the quality of connections used around the source impedance is one area of potential inaccuracy,

given the low value of the reference impedance itself. In addition, the power source needs to produce a sinusoidal voltage of very high quality under all load conditions. Attempting to perform a harmonics test using a voltage supply derived from the mains (e.g. through an isolation transformer or power filter) is unlikely to be adequate. Other easily made errors include setting the wrong frequency (60 Hz instead of 50 Hz) or voltage (110 Vac instead of 230 Vac) on the power source.

Should discrepancies arise between tests, each element of the test setup would need to be examined. If, for example, the flicker Pst value has changed, but the voltage deviation has not, then has the calculation changed in any way? Or, if the voltage deviation has changed, this could indicate a change in either the source or the source impedance, of which the source can be checked in isolation, under load conditions, using standard laboratory equipment.

The HFG01 is designed to run solely from a 230 Vac, 50 Hz supply and any deviations from this will inevitably affect the harmonic spectrum or flicker levels produced.